

# POWER OTTOMAN

instruction manual and care guide



## Easy set up instructions for your new Ottoman bed

THIS INSTRUCTION PACK IS UNIVERSAL ACROSS THE RANGE  
IMAGE USED MAYBE DIFFERENT FROM THE ONE IN PACK



ASSEMBLY  
INSTRUCTIONS



REF CODE: LEAFLET  
FHL - IN-UPH-EO

Information, diagrams and steps illustrated in this Assembly Guide  
are correct at the time of publication.



# Introduction and components



1. Unpack in the room the bed is intended to be used, remove all packaging and dispose of carefully, keeping polythene out of the reach of children.

## CONTENTS:

- 1 x Head board
- 1 x Foot board
- 2 x Side Rails
- 2 x Base boards
- 1 x Support Bar
- 1 x Transformer
- 1 x Power cable with 3 Pin Plug
- 1 x Extension cable
- 2 x 9v Batteries
- 4 x M8 Nuts
- 4 x M8 Bolts
- 2 x Brace Bars
- 6 x Washers
- 3 x Fixing Nuts
- 3 x Fixing Bolts
- 4 x Flange Nuts
- 4 x Allen Key Bolts

## SAFETY FEATURES:

Your bed is fitted with a child lock on the button controller on the side. Activating the child lock will prevent the base lifting when the buttons are pressed. **our bed will be delivered and installed with the child lock activated, you will need to de-activate the lock before using for the first time.**



### **DANGER – RISK OF INJURY / CRUSHING**

The ottoman must only be operated by responsible and capable adults.

Never allow children to operate the ottoman.  
**Always engage the child safety lock when the ottoman is not in use.**

**To activate Child Lock;**  
press small hole with pointed object (like the sort of thing you'd remove a sim card from your mobile phone with)



Once **activated** the Green Light will turn off.



**Turn off the Child Lock** by repeating this step.



## TOOLS REQUIRED

The following tools are required for this assembly  
1 x Socket Set - 13mm Spanner  
1 x Cross Head Screwdriver (also known as a Phillips)



## CAUTION WITH ASSEMBLY

Some stages of this Bed Assembly will require two people to hold and lift components that maybe heavy.

## CHECK LIST - BED ASSEMBLY

Please check the pack contents before attempting to assemble this product.

If any components are missing, please contact the retailer from whom you bought this product.

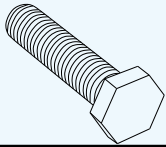

M8 FIXING-BOLT  
= x4

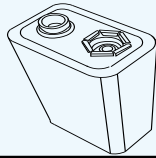

BATTERY-9V = X2  
For the Transformer

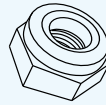

M8 FIXING-NUT  
x4

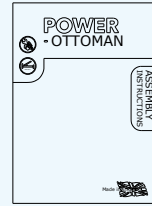

ASSEMBLY GUIDE  
= x1



EXTENSION CABLE  
= x1

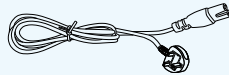

POWER CABLE  
= x1

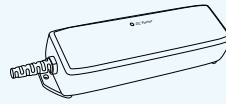

TRANSFORMER  
= x1

## CHECK LIST - FRAME ASSEMBLY

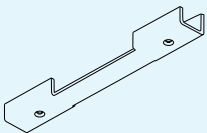

BRACE-BAR  
= x2



WASHER  
= x6



FIXING-NUT  
= x3

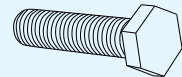

FIXING-BOLT  
= x3



FLANGE NUT  
= x4

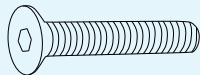

ALLEN KEY BOLT  
= x4

**This product is HEAVY, it should be assembled as near as possible to the point of use. TAKE CARE WHEN LIFTING to avoid personal injury and (or) damage to the product.**

This product takes approximately 60 - 90 MINUTES to assemble with 2 PEOPLE.

The fittings pack contains SMALL ITEMS which should be **KEPT AWAY FROM YOUNG CHILDREN.**

Read this leaflet in full before commencing assembly.



**FOR SLATTED SLATTED FRAME OPTION, FOLLOW STEPS BELOW  
FOR BISCUIT PLATFORM OPTION SKIP TO STEP 7**

\*We recommend flipping the slatted frames for easier access to bolt holes.

4. Your slatted frame will arrive in two sections and are **required to be connected together** by following the next steps.

5. On each of the points - use **one** fixing bolt **two washers** and **one fixing nut** to secure the frame together.

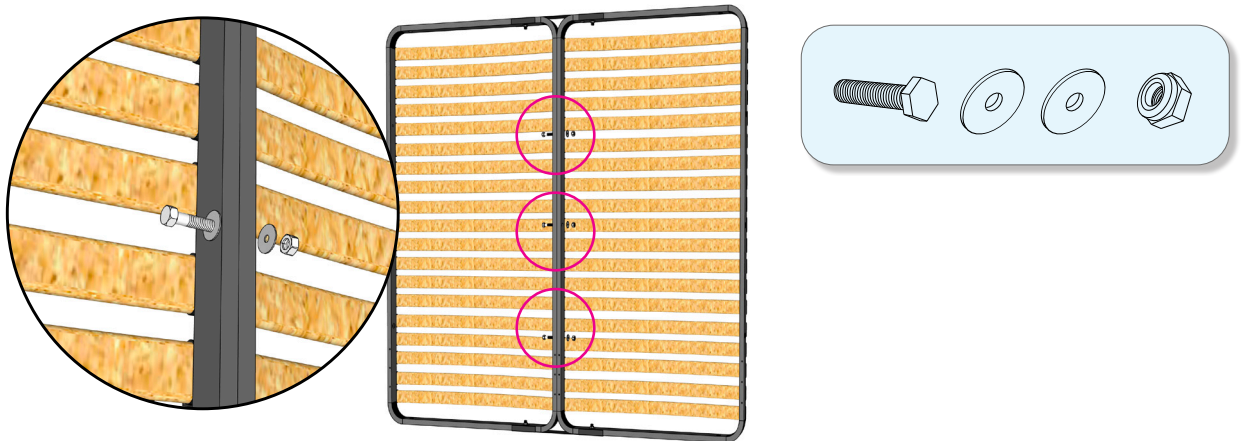

6. Place the two brace bars onto the slatted frame at each end. These are fixed by the allen key bolts supplied in the bag.

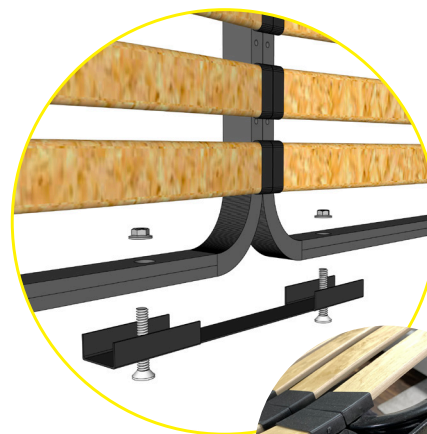
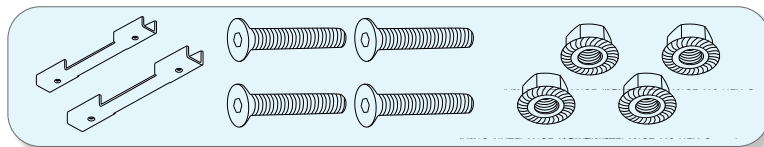

\* Line up the bolts into the brace & frame on both sides before tightening using the supplied flange nuts.



## The hinge brackets will already be fixed into place.

**Please Note:** You are required to follow the steps as detailed to make sure that the bed is correctly set up.

### Left Hand Bracket

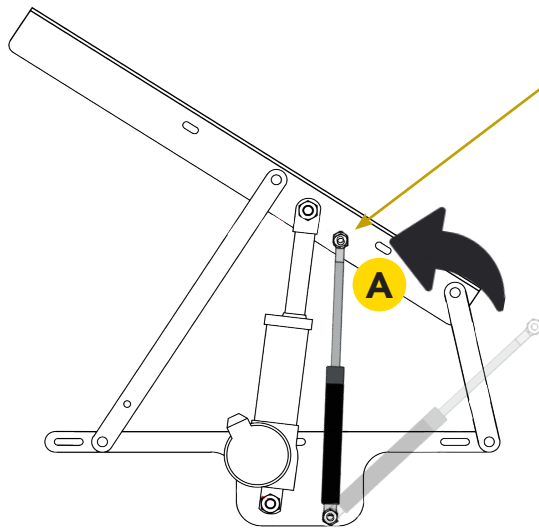

5.

- 1 . Remove the M8 Nut on position **A**
- 2 . Move the gas strut into the position **A**
- 3 . Place the M8 Nut and tighten with 13mm Spanner

### Right Hand Bracket

6.

- 1 . Remove the M8 Nut on position **B**
- 2 . Move the gas strut into the position **B**
- 3 . Place the M8 Nut and tighten with 13mm Spanner

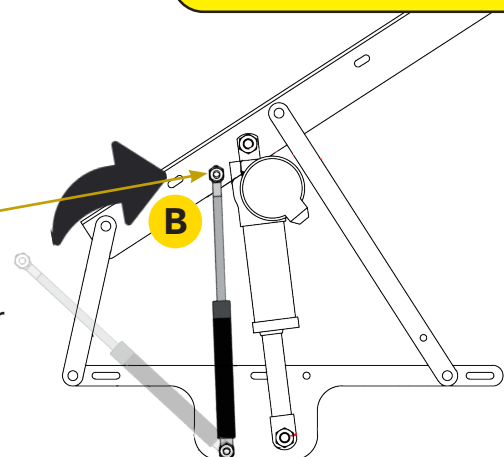

**\*\* IF YOUR BED IS SUPPLIED WITH HIGH FOOTBOARD, YOU NEED TO SCREW THE SUPPLIED LEGS TO THE BOTTOM OF THE HEADBOARD & FOOTBOARD**



**Please Note:** this step will require two people and requires lifting.

**7.** Connect the side rails to the **headboard** sliding the bolts into the brackets and tightening with spanner or appropriate socket set.

Then proceed to connect the footboard to both of the siderails by sliding the bolts into brackets and tightening with the correct size spanner.

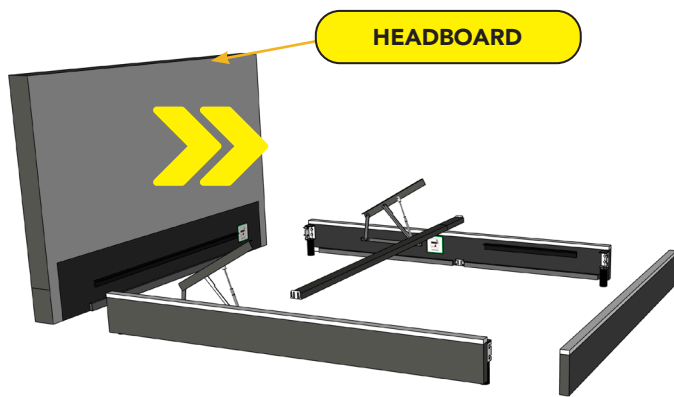

**\*\* Internal legs come with low footboard beds only**

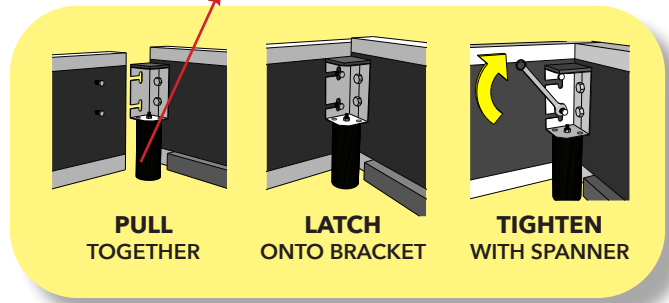

**\*\*Do not tighten bolts to one side until step 7**

**8.** Lower the **support bar** into the middle section of the bed.

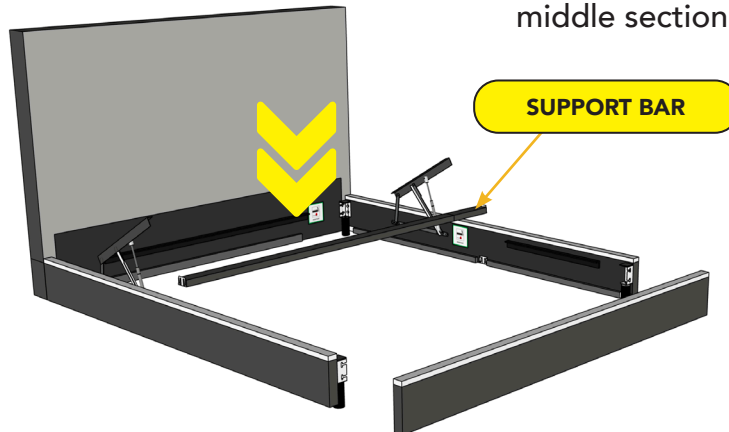

**\*\* Internal legs come with low footboard beds only**

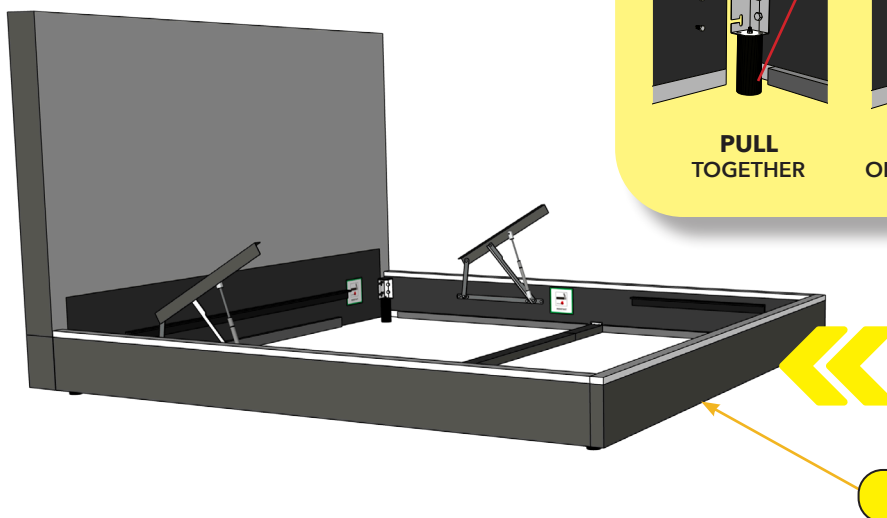
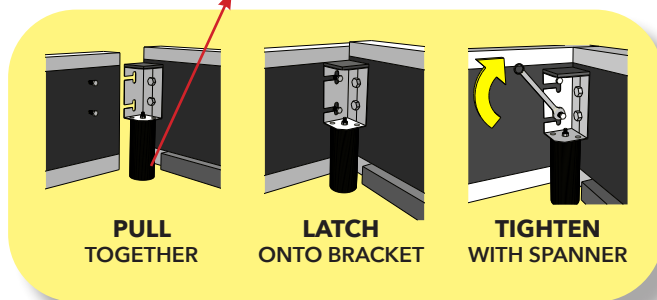

## 9. Connect the electric cables before placing the base boards into your bed.

**A.** Connect the the two leads that link the motors on each of the side rails. Make sure your cable run along the side rail and are clear of the hinge bracket



**B.** Connect the cable to the switch controller.

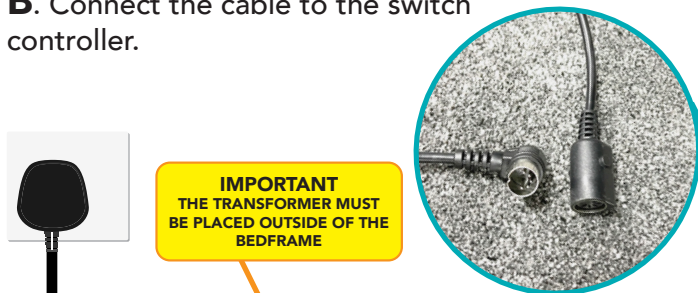

**C.** Connect the transformer to the bed.



**10.** Insert the 2 x 9v batteries supplied into the transformer. **The batteries provide an emergency back-up allowing you to lower the bed base in the event of a power cut.**

The batteries are **NOT** to be used as an alternative to the mains power supply. The batteries will provide enough power for 1 or 2 lifts, and should be removed and replaced when they have been used.

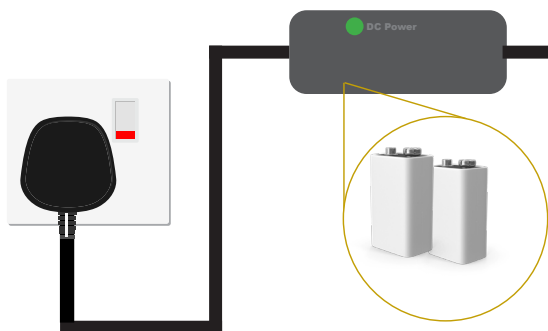

**11.** Remove the childlock advisory sticker.



Once activated the Green Light will turn off.



Turn off the Child Lock by repeating this step.



To activate Child Lock; press small button with pointed object (e.g Nib of a Ballpoint Pen)

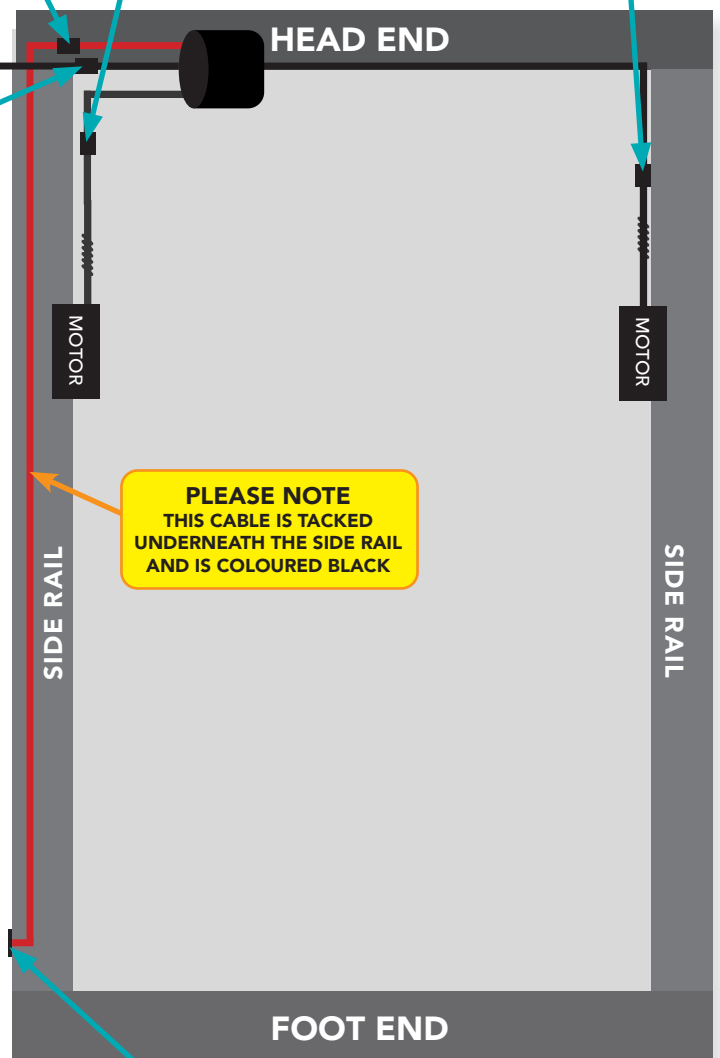



**Please Note:** this step will require two people and requires lifting.

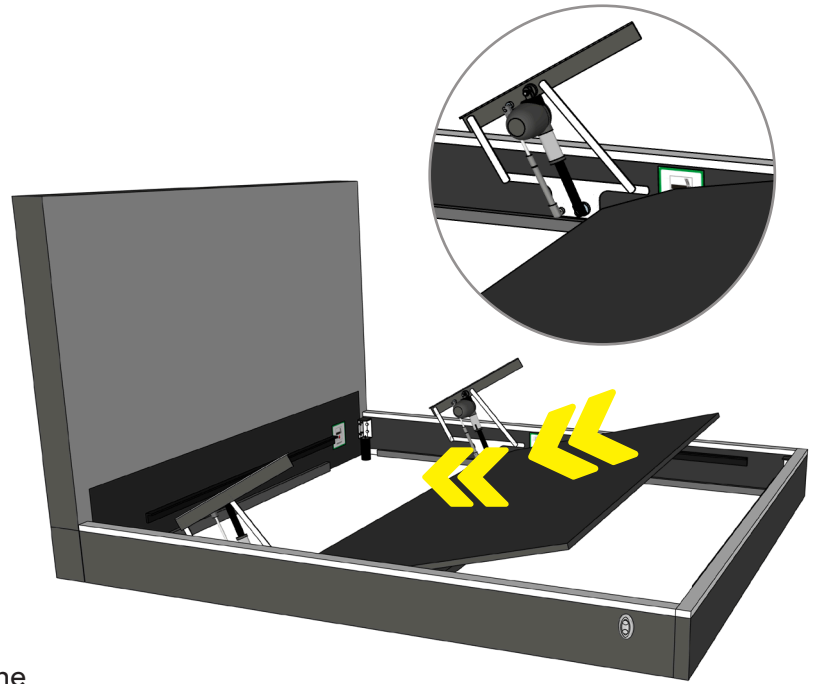

**12.** Lower the **first** base board into place with the angled cut corners against the head board (as shown above).

Make sure that the cables from the motors are laying on the top of the base board and are not behind the hinge unit.

**13.** Lower the **second** base board into place with the angled cut corners against the head board (as shown below).

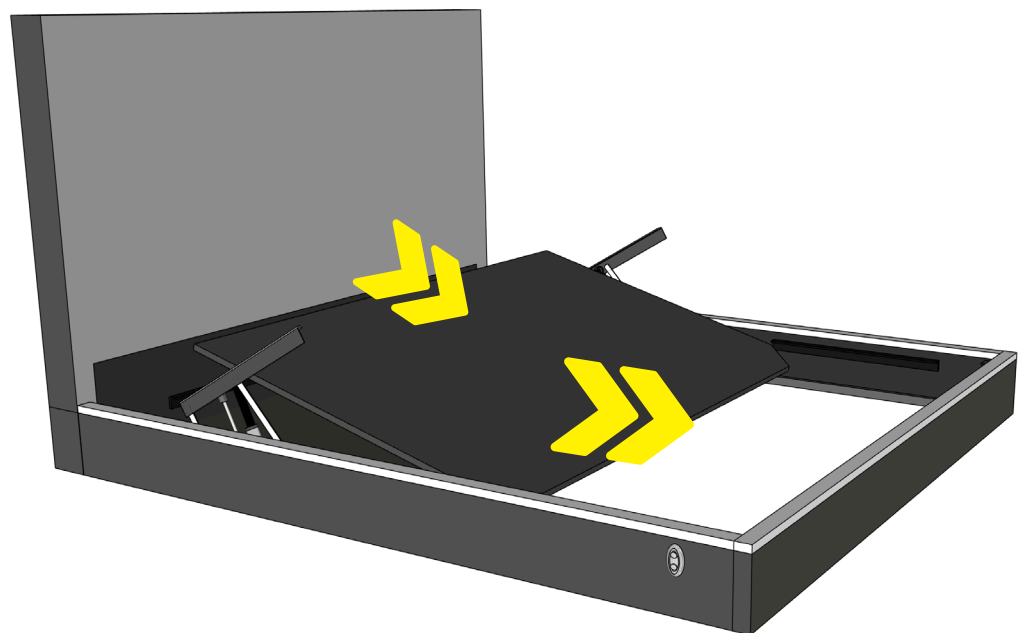





**Please Note:** this step will require two people and requires lifting.

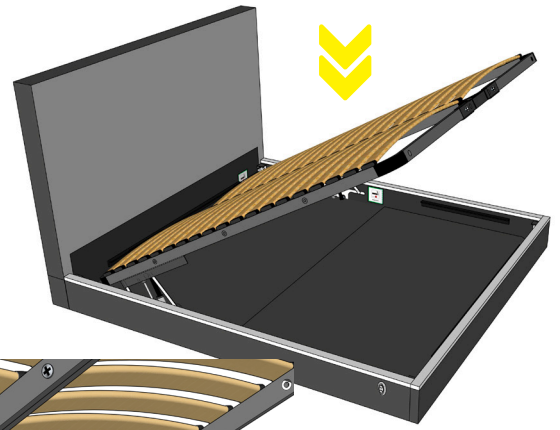

**14.** With help, lower the slatted base onto the two rails (attached to the motorised hinge).  
**Make sure that the welded retaining brackets are at the headboard end.**

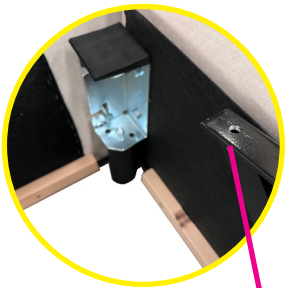
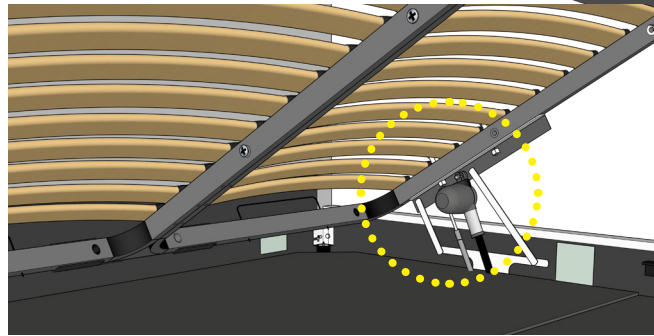

Please make sure you thread this hole on each side. **DO NOT USE** the end two holes.

**15.** Using the 4 x M8 Bolts and Nuts, attach the slatted frame to each of the hinge brackets; 2 x M8 Bolts & Nuts to each hinge.

- You will need to use a 13 mm spanner/ socket set in order to tighten each of the bolts.

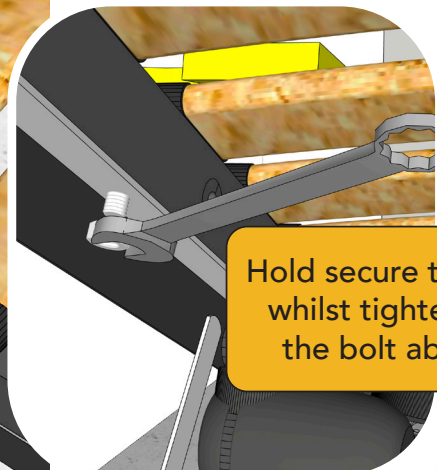
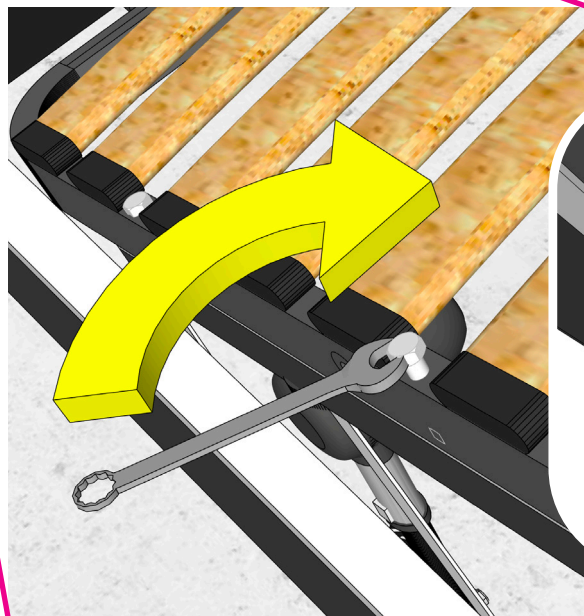
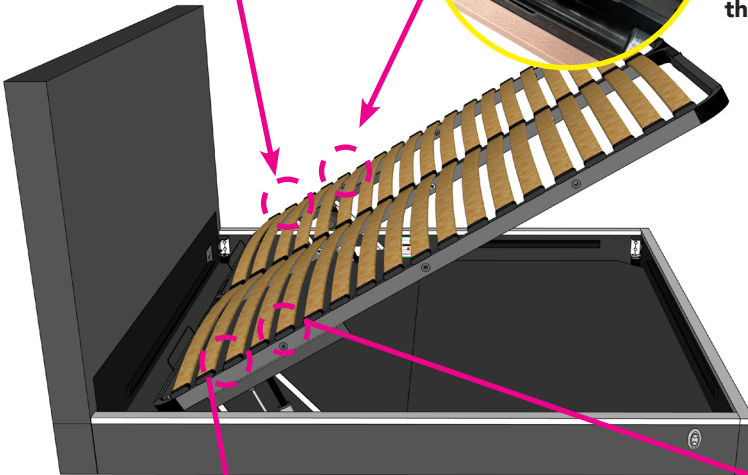

## YOUR BED WILL ONLY LOWER ONCE THE MATTRESS IS IN PLACE



**Please Note:** this step will require two people and requires lifting.

**16.** Lower your mattress onto the slatted frame.

**\*\* Recommended mattress weight to be at least 45kg to allow for the pistons to work properly.**

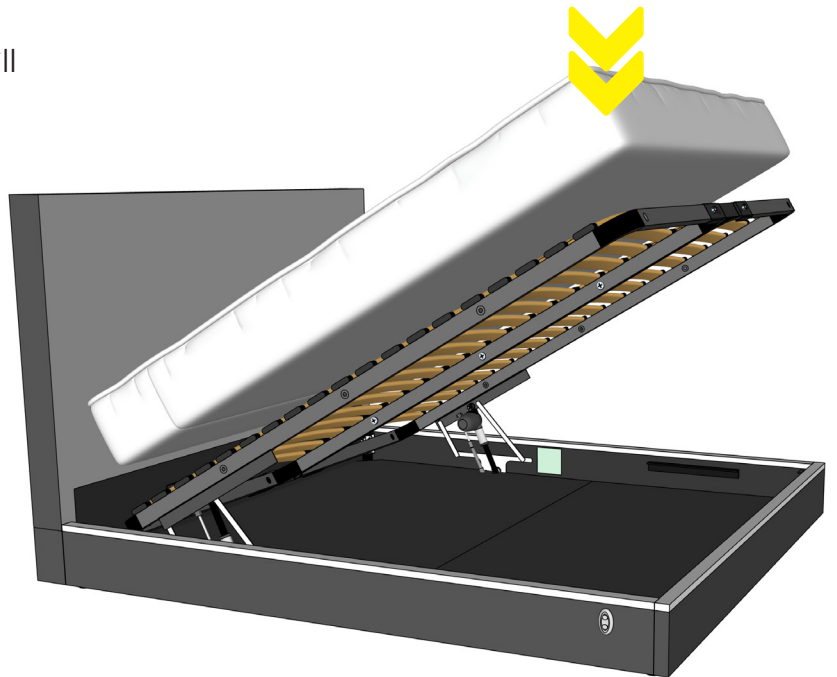

**17.** Plug in the power lead from the transformer and lower the bed.

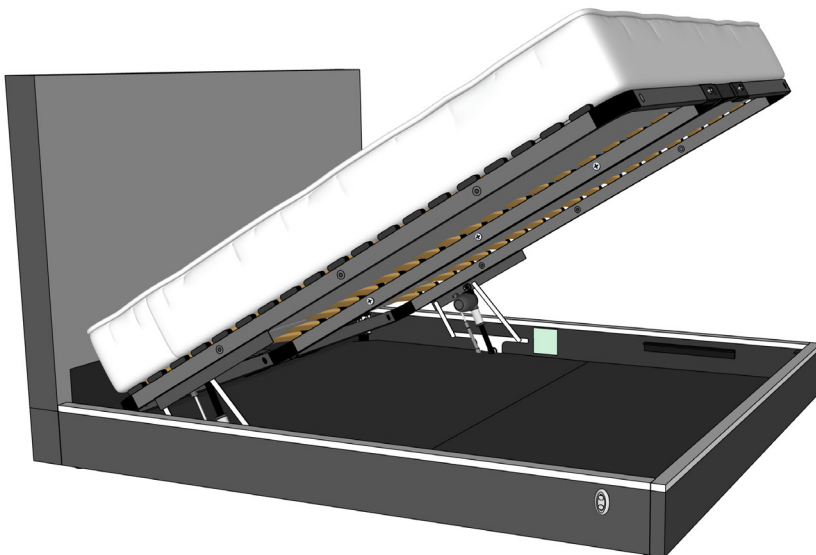

**18.** Once tested, your bed is ready for use.



## DANGER — RISK OF INJURY / CRUSHING

The ottoman must only be operated by responsible and capable adults.  
Never allow children to operate the ottoman. Always engage the child safety lock when the ottoman is not in use. Refer to the Care Manual for safety lock instructions.



MADE WITH OVER  
**50**  
YEARS OF  
EXPERIENCE & EXPERTISE  
ESTABLISHED 1968



# MATTRESS CARE GUIDE



- ✓ **Turn your mattress** over completely every 2 weeks for the first 3 months, both side to side and head to toe, then every other month thereafter. With no-turn mattresses, rotate head to toe.
- ✓ **Air your bed thoroughly** once a month by stripping the bedclothes and leaving for a few hours.
- ✓ **Use a mattress protector** to prolong the life of your bed. As the mattress materials need to breathe, we would suggest you avoid using plastic-based sheeting, as this will lead to damage caused by condensation.

**Mattress maintenance** plays an important role in extending the lifespan of your mattress, as well as ensuring you get optimum comfort while sleeping.

Once you and your new mattress have got to know each other, we recommend some maintenance tips to ensure your mattress lasts for as long as possible. These include rotating and/or turning over your mattress, cleaning your mattress, and airing it out.

- ✗ Don't sit on the edge of your mattress. They are designed to have weight spread over the whole area.
- ✗ Don't bend or roll your mattress, this can cause damage to the spring unit and tear the material.
- ✗ Don't walk or jump on your bed and please don't let children use it as a trampoline!



**Hestia**<sup>®</sup>  
LIVING

## Natural Tufted Range of Mattress

Do not worry if hollows appear in the sleeping areas of your mattress. This is quite normal and is not a fault. Due to the top layers consisting of wool/silk and cotton, it is important that the mattress is kneaded to bring it back to its original condition each month. This will reduce the amount of natural settlement that will happen.

WWW.HESTIALIVING.CO.UK





# Your Guarantee

We are delighted that you have bought one of Furmanac Hestia Living British, quality handmade beds.



We're so confident in the quality of our workmanship that every upholstered bed comes with our 7 Year Frame and Frame Construction Guarantee. This covers the timber frame and frame construction on models. In addition, all motion mechanisms, electric motors and power packs come with a 5-year warranty.

Our skilled craftsmen have created furniture of outstanding quality for over 50 years and we hope you enjoy its comfort and style for many years to come.



For full details on this Guarantee\* please visit: [www.hestialiving.co.uk](http://www.hestialiving.co.uk)